



HydroStor[®]

STORMWATER CHAMBER



PRINSCO Storm
WATER MANAGEMENT SOLUTIONS



Our Values



the
Prinsco
difference
service led by values

The Prinsco Difference isn't just about service, it's about a way of doing business. As a family-owned company, we operate by our core values of hard work, integrity, relationships, and humility. This means we go beyond transactions to build genuine partnerships with our customers. We believe in working tirelessly, acting with honesty, fostering strong connections, and approaching every challenge with a willingness to learn. It's this foundation that allows us to provide exceptional service and solutions you can trust.

Corporate Headquarters

1717 16th Street NE
Willmar, MN 56201

Phone: 320.222.6800

Toll Free: 800.992.1725

Fax: 320.222.6820

prinsco.com



Introduction

Performance, System Design, Handling	5
Which Chamber is Right for Your Project	6
Footprint Comparison	7

Chambers

HydroStor® HS31.....	8-9
HydroStor® HS75.....	10-11
HydroStor® HS180.....	12-13
HydroStor® HS290.....	14-15

Education

Sediment Row	16
System Cleaning	16
Tech Centers.....	17
Engineering Tech Center	17
Research Tech Center.....	17

Shipping Information

Prinsco Delivers Quality.....	18
48' Trailer	18
53' Trailer.....	18

Appendix

Notes	19
-------------	----





Prinsco's chamber systems can be easily modeled with the HydroCAD Stormwater Modeling System and the Civil 3D AutoCAD Module. Both tools simplify the process of designing a system meeting specific storage and footprint requirements.



Performance

- High performance polypropylene material
- Meets or exceeds ASTM F2418 product standard & ASTM F2787 design standard
- Meets AASHTO H20 live load & HL93 design load requirements
- Advanced injection molding technology for maximum structural performance

System Design

- Maximum land utilization & minimal environmental impact
- Smaller footprint with lower installed cost than similar underground retention/detention systems
- Four chamber options to accommodate a variety of system volumes and burial depths
- Design tool available at Prinsco.com/HydroStor-Resources
- Available as part of a complete solution with end caps, pipe manifolds & pretreatment options

Handling

- Integrated handles for safe on-site handling
- Sturdy and lightweight for safe transport and placement by 2 people
- Specially designed pallet for trouble free handling
- Maximum stacking density to reduce on-site staging footprint
- Minimizes shipping costs

Which Chamber is Right for Your Project

This decision tree can help to get your start on picking the right chamber size for your project. After selecting a size, contact your local sales rep to ensure it meets your project requirements

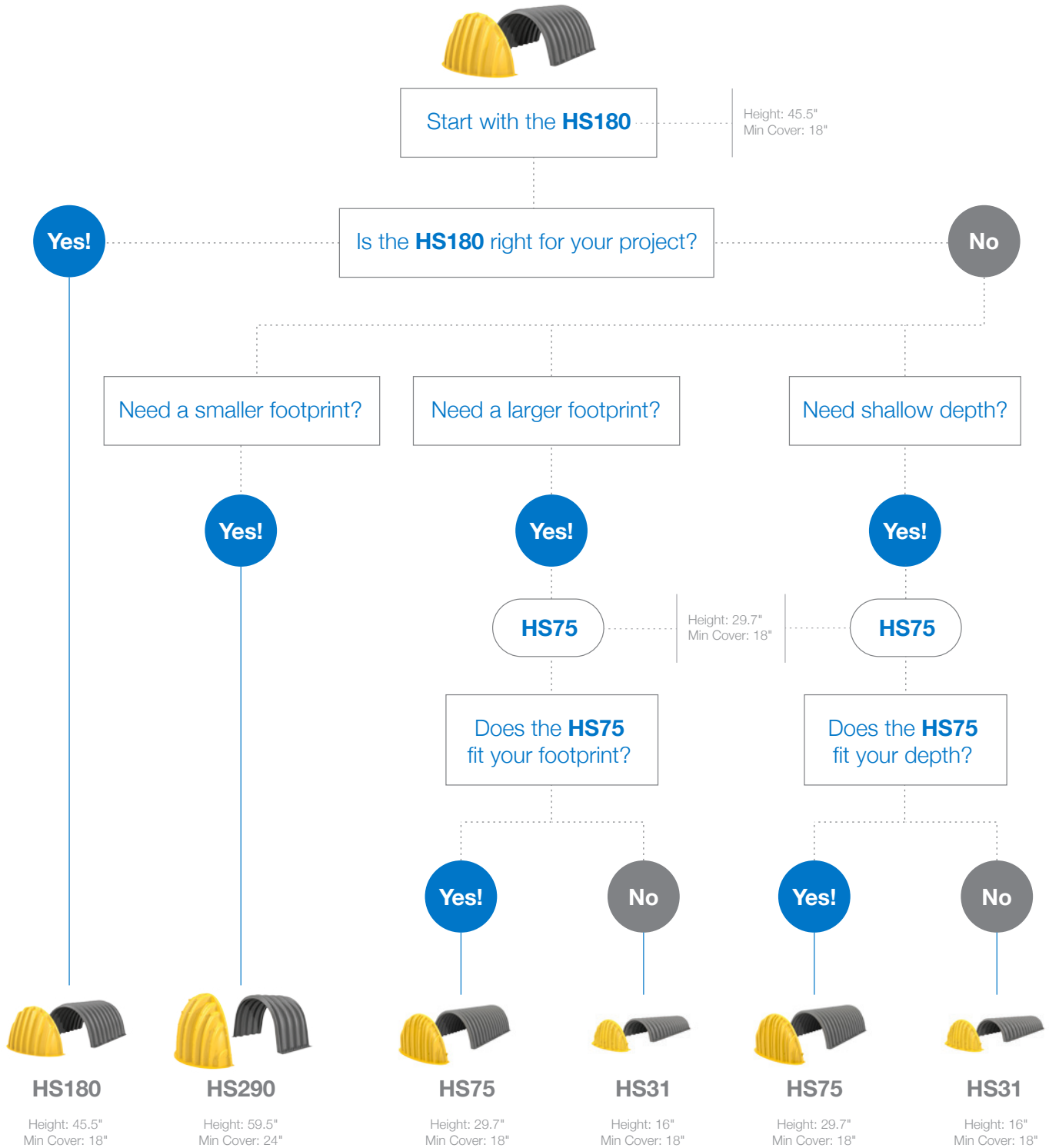

Footprint Comparison

Prinsco offers four chamber sizes to meet various project needs. Here you can see how dramatically the selection of the chamber size effects the footprint of a system with the same storage volume:

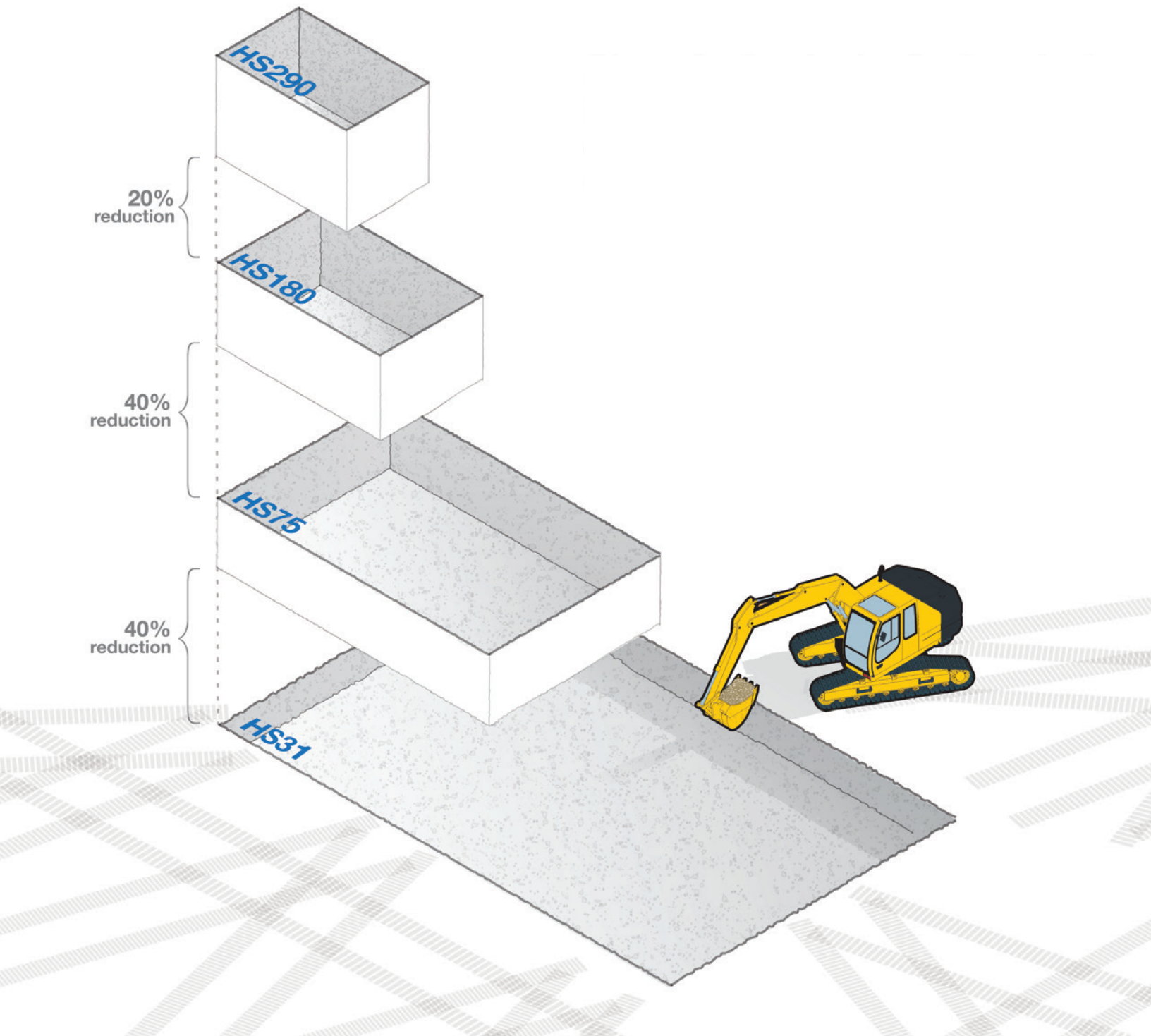



HydroStor[®] | HS31

Features & Benefits

- For low profile applications
- High performance polypropylene material
- Meets or exceeds **ASTM F2418** product standards & **ASTM F2787** design standards
- Meets **AASHTO H20** live load & **HL93** design load requirements



Chamber Specifications

Height (A)	16" (406 mm)	Storage per Lin. Ft.	2.13 ft ³ /ft (0.20 m ³ /m)	Maximum Burial Depth (F) ³	8' (2.4 m)
Width (B)	34" (864 mm)	Storage per Chamber	15.2 ft ³ /chamber (0.43 m ³ /chamber)	Stone Void Volume ⁴	2.26 ft ³ /ft (0.21 m ³ /m)
Installed Length	85.5" (2,172 mm)	Installed Storage per Lin. Ft.	4.39 ft ³ /ft (0.41 m ³ /m)	Weight	34 lbs (15.4 kg)
Bedding (C)	6" (150 mm)	Installed Storage per Chamber	31.2 ft ³ /chamber (0.88 m ³ /chamber)	Material	Polypropylene
Chamber Spacing (D)	6" (150 mm)	Minimum Cover Height ² (E)	18" (450 mm)	MFG Method	Injection Molded
Chamber Embedment Backfill ¹	6" (150 mm)	Minimum Installed Depth to Base of Stone	40" (1,016 mm)	ASTM Spec(s)	ASTM F2418 ASTM F2787

¹Used in Installed Storage Calculations ²Measured from top of chamber to bottom of pavement ³Measured from the top of chamber to the top of pavement ⁴Assumes 40% porosity

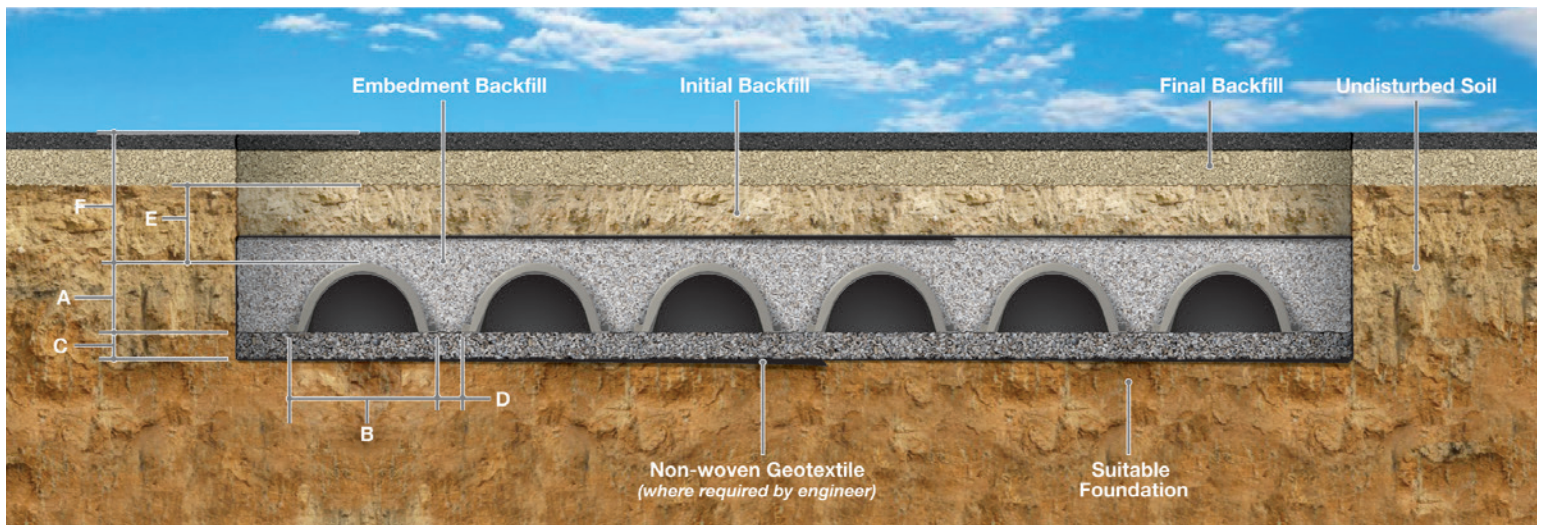

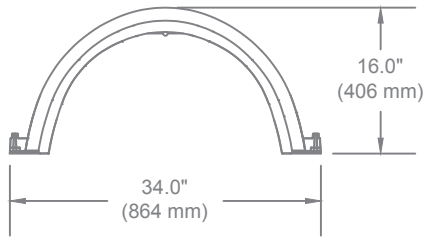

HydroStor® HS31 end view

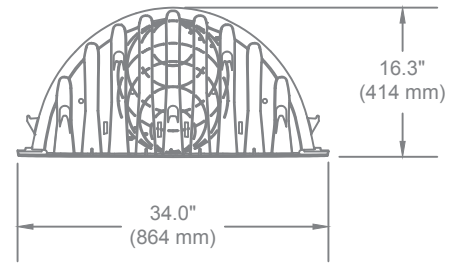

HydroStor® HS31 end cap end view

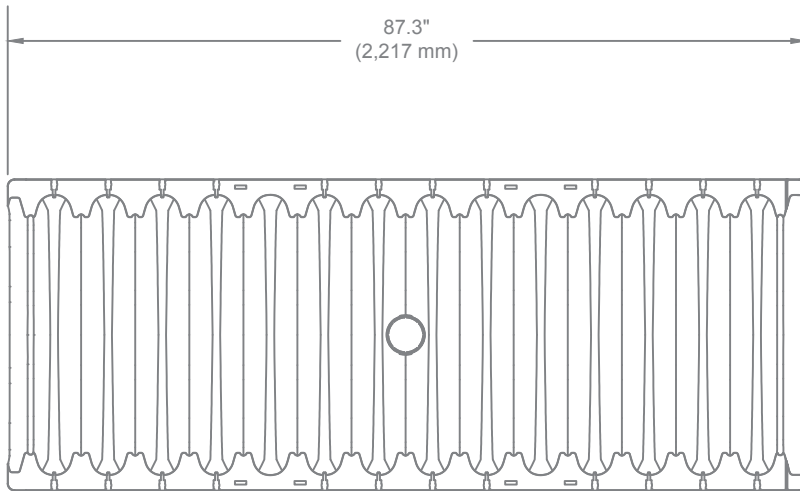

HydroStor® HS31 top view



HydroStor® HS31 end cap side view

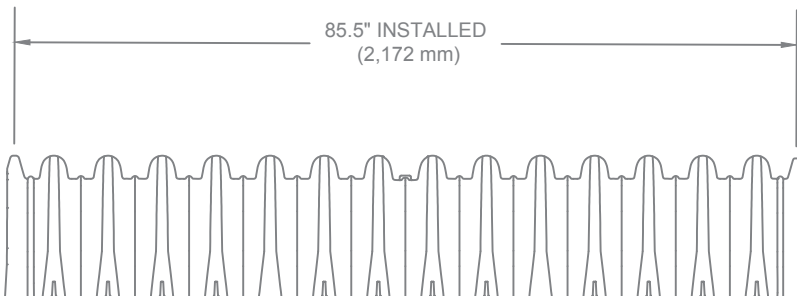

HydroStor® HS31 side view

End Cap Specifications

End Cap Size (L x W x H)	8" x 34" x 16.3" (200 x 864 x 414 mm)
Installed Length	6.9" (180 mm)
End Cap Storage	0.62 ft ³ (0.02 m ³)
Minimum Installed Storage	5.19 ft ³ (0.15 m ³)
Weight	3.8 lbs (1.7 kg)

Shipping

Chambers/Pallet	90 Chambers
End Caps/Pallet	60 End Caps



HydroStor® | HS75

Features & Benefits

- Integrated handles for safe on-site handling
- High performance polypropylene material
- Meets or exceeds **ASTM F2418** product standards & **ASTM F2787** design standards
- Meets **AASHTO H20** live load & **HL93** design load requirements



Chamber Specifications

Height (A)	29.7" (754 mm)	Storage per Lin. Ft.	6.59 ft ³ /ft (0.61 m ³ /m)	Maximum Burial Depth (F) ³	8' (2.4 m)
Width (B)	51" (1,295 mm)	Storage per Chamber	46.6 ft ³ /chamber (1.32 m ³ /chamber)	Stone Void Volume ⁴	4.02 ft ³ /ft (0.37 m ³ /m)
Installed Length	84.9" (2,156 mm)	Installed Storage per Lin. Ft.	10.6 ft ³ /ft (0.98 m ³ /m)	Weight	69 lbs (31.3 kg)
Bedding (C)	6" (150 mm)	Installed Storage per Chamber	75 ft ³ /chamber (2.12 m ³ /chamber)	Material	Polypropylene
Chamber Spacing (D)	6" (150 mm)	Minimum Cover Height ² (E)	18" (450 mm)	MFG Method	Injection Molded
Chamber Embedment Backfill ¹	6" (150 mm)	Minimum Installed Depth to Base of Stone	54" (1,372 mm)	ASTM Spec(s)	ASTM F2418 ASTM F2787

¹Used in Installed Storage Calculations ²Measured from top of chamber to bottom of pavement ³Measured from the top of chamber to the top of pavement ⁴Assumes 40% porosity

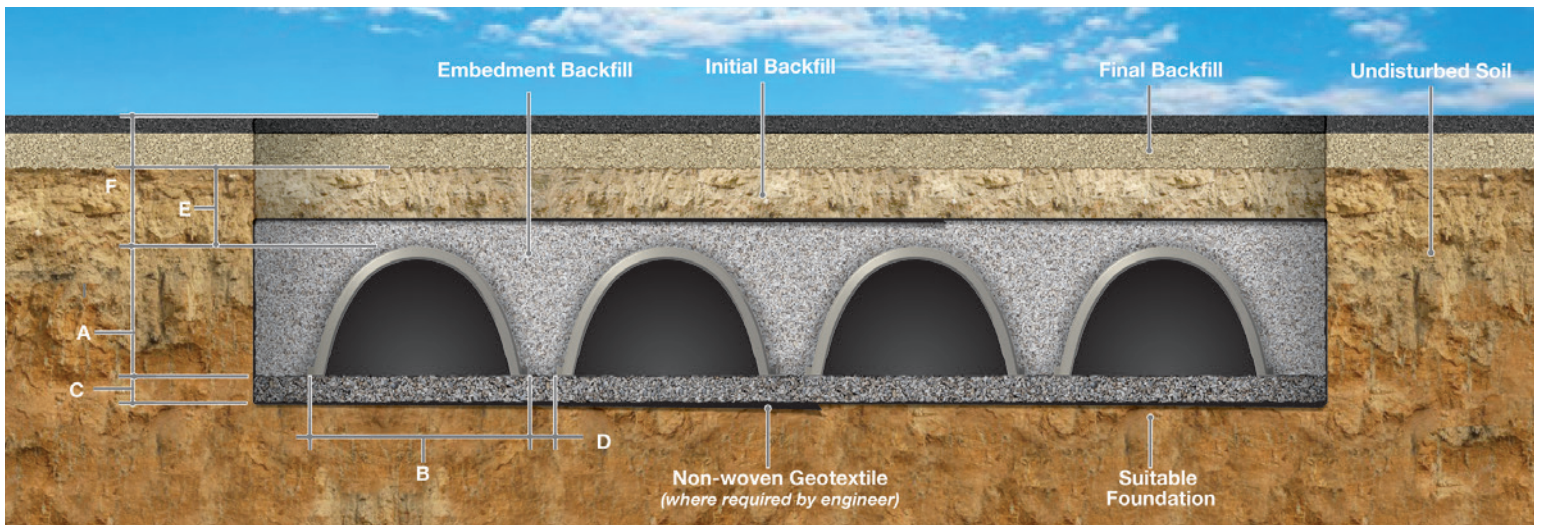

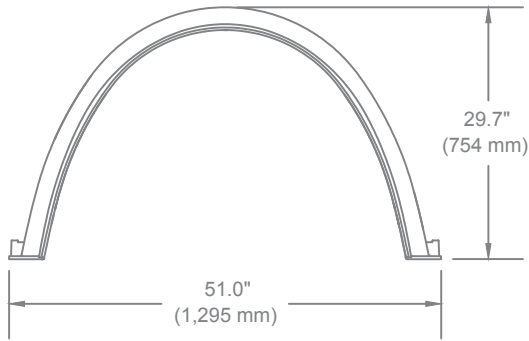

HydroStor® HS75 end view

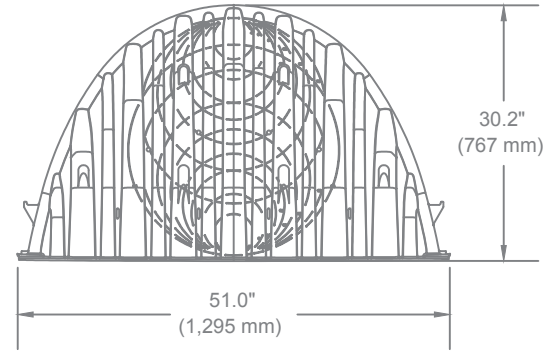

HydroStor® HS75 end cap end view

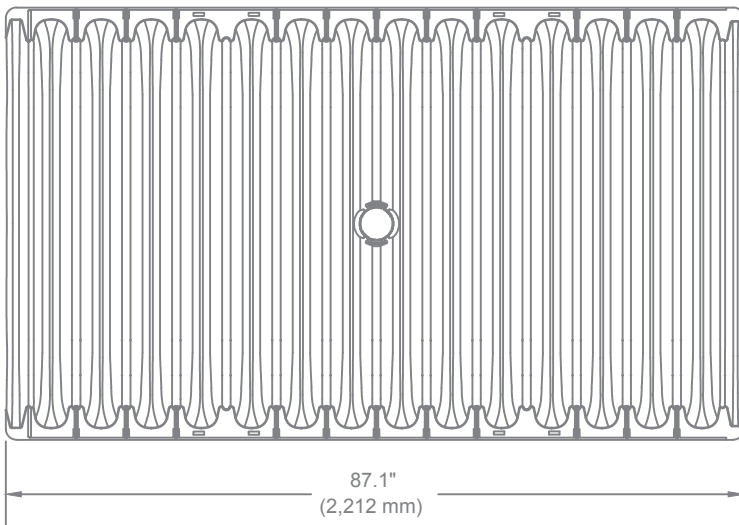

HydroStor® HS75 top view

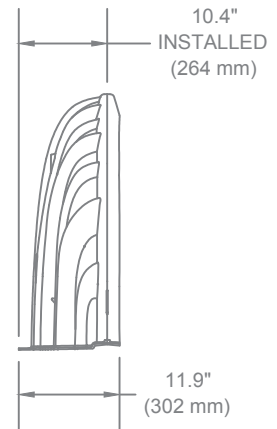

HydroStor® HS75 end cap side view

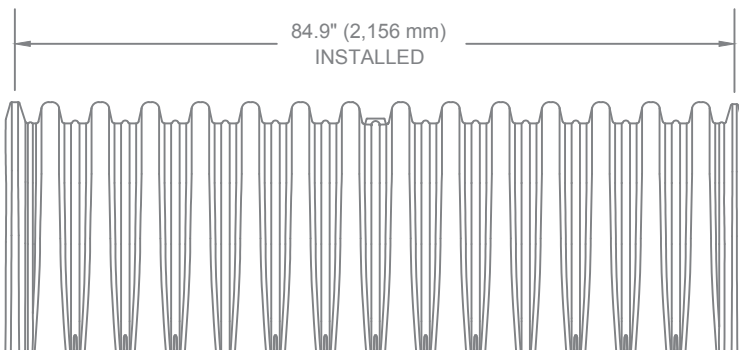

HydroStor® HS75 side view

End Cap Specifications

End Cap Size (L x W x H)	11.9" x 51" x 30.2" (302 x 1,295 x 767 mm)
Installed Length	10.4" (264 mm)
End Cap Storage	3.42 ft ³ (0.09 m ³)
Minimum Installed Storage	14.5 ft ³ (0.41 m ³)
Weight	13.2 lbs (5.99 kg)

Shipping

Chambers/Pallet	33 Chambers
End Caps/Pallet	20 End Caps



HydroStor® | HS180

Features & Benefits

- Integrated handles for safe on-site handling
- High performance polypropylene material
- Meets or exceeds **ASTM F2418** product standards & **ASTM F2787** design standards
- Meets **AASHTO H20** live load & **HL93** design load requirements



Chamber Specifications

Height (A)	45.5" (1,156 mm)	Storage per Lin. Ft.	15.98 ft ³ /ft (1.48 m ³ /m)	Maximum Burial Depth (F) ³	8' (2.4 m)
Width (B)	77.8" (1,976 mm)	Storage per Chamber	113.6 ft ³ /chamber (3.2 m ³ /chamber)	Stone Void Volume ⁴	8.78 ft ³ /ft (0.82 m ³ /m)
Installed Length	85.3" (2,167 mm)	Installed Storage per Lin. Ft.	24.76 ft ³ /ft (2.30 m ³ /m)	Weight	122 lbs (55.3 kg)
Bedding (C)	9" (230 mm)	Installed Storage per Chamber	176 ft ³ /chamber (4.98 m ³ /chamber)	Material	Polypropylene
Chamber Spacing (D)	5" (130 mm)	Minimum Cover Height ² (E)	18" (450 mm)	MFG Method	Injection Molded
Chamber Embedment Backfill ¹	12" (300 mm)	Minimum Installed Depth to Base of Stone	72.5" (1,841 mm)	ASTM Spec(s)	ASTM F2418 ASTM F2787

¹Used in Installed Storage Calculations ²Measured from top of chamber to bottom of pavement ³Measured from the top of chamber to the top of pavement ⁴Assumes 40% porosity

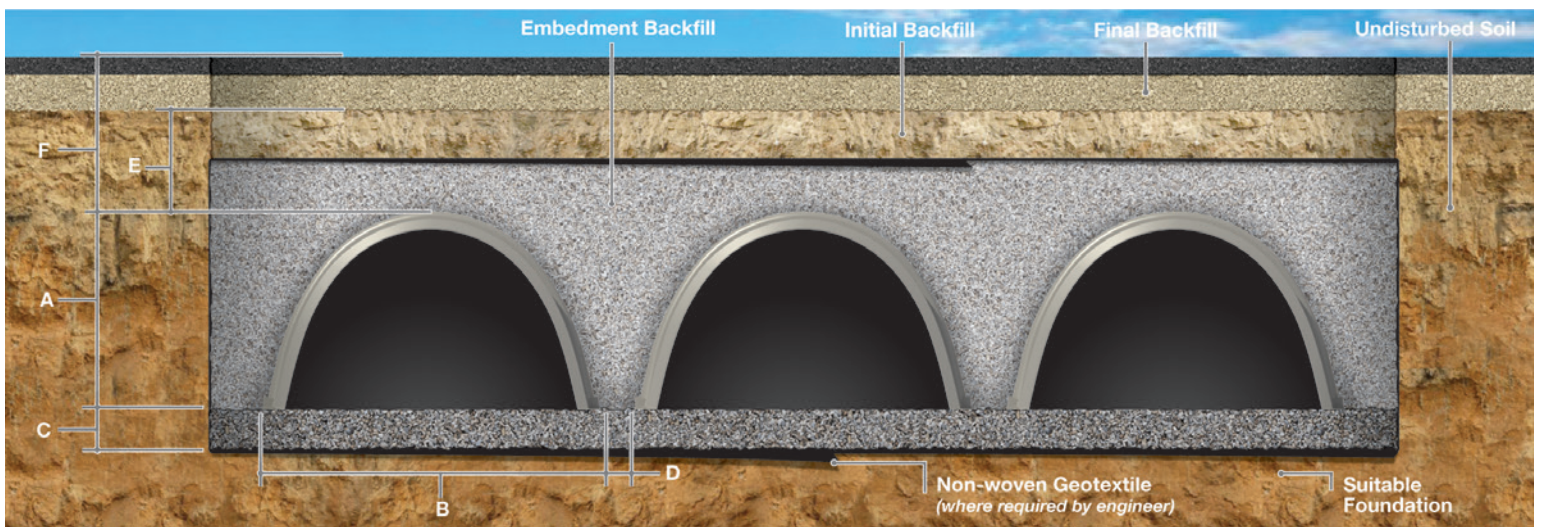

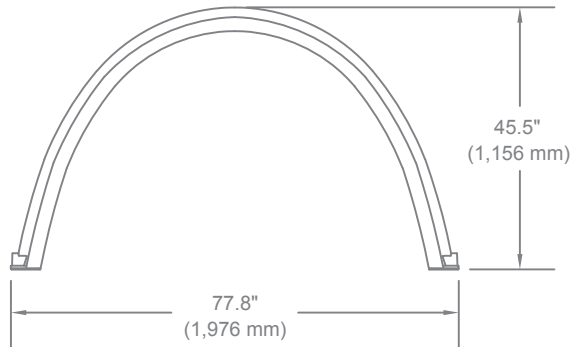

HydroStor® HS180 end view

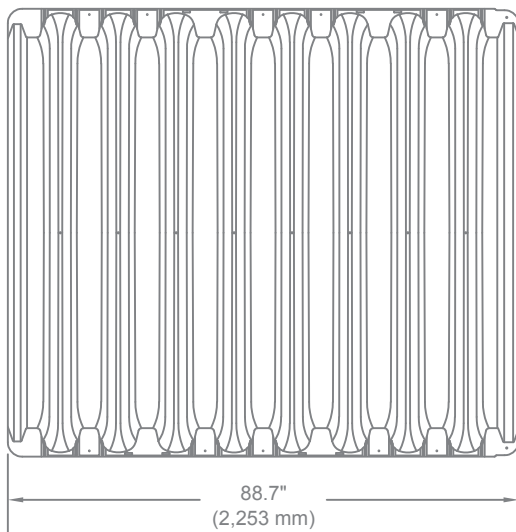

HydroStor® HS180 top view

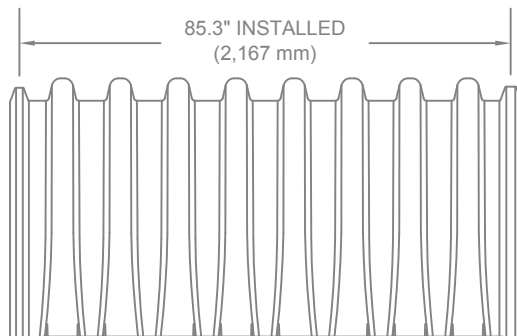

HydroStor® HS180 side view

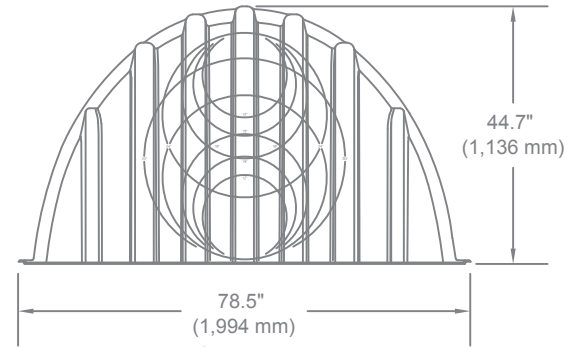

HydroStor® HS180 end cap end view

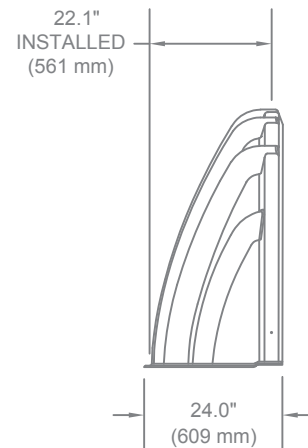

HydroStor® HS180 end cap side view

End Cap Specifications

End Cap Size (L x W x H)	24" x 78.5" x 44.7" (609 x 1,994 x 1,136 mm)
Installed Length	22.1" (561 mm)
End Cap Storage	15.3 ft ³ (0.4 m ³)
Minimum Installed Storage	44.8 ft ³ (1.3 m ³)
Weight	52 lbs (23.6 kg)

Shipping

Chambers/Pallet	19 Chambers
End Caps/Pallet	12 End Caps



GUIDELINES



HydroStor HS290



HydroStor[®] | HS290

Features & Benefits

- Minimal footprint
- Integrated handles for safe on-site handling
- High performance polypropylene material
- Meets or exceeds **ASTM F2418** product standards & **ASTM F2787** design standards
- Meets **AASHTO H20** live load & **HL93** design load requirements



Chamber Specifications

Height (A)	59.5" (1,511 mm)	Storage per Lin. Ft.	27.23 ft ³ /ft (2.5 m ³ /m)	Maximum Burial Depth (F) ³	8' (2.4 m)
Width (B)	100.5" (2,553 mm)	Storage per Chamber	109.6 ft ³ /chamber (3.1 m ³ /chamber)	Stone Void Volume ⁴	13.64 ft ³ /ft (1.27 m ³ /m)
Installed Length	48.3" (1,227 mm)	Installed Storage per Lin. Ft.	40.87 ft ³ /ft (3.8 m ³ /m)	Weight	112 lbs (50.8 kg)
Bedding (C)	9" (230 mm)	Installed Storage per Chamber	164.5 ft ³ /chamber (4.66 m ³ /chamber)	Material	Polypropylene
Chamber Spacing (D)	8.5" (220 mm)	Minimum Cover Height ² (E)	24" (600 mm)	MFG Method	Injection Molded
Chamber Embedment Backfill ¹	12" (300 mm)	Minimum Installed Depth to Base of Stone	92.5" (2,350 mm)	ASTM Spec(s)	ASTM F2418 ASTM F2787

¹Used in Installed Storage Calculations ²Measured from top of chamber to bottom of pavement ³Measured from the top of chamber to the top of pavement ⁴Assumes 40% porosity

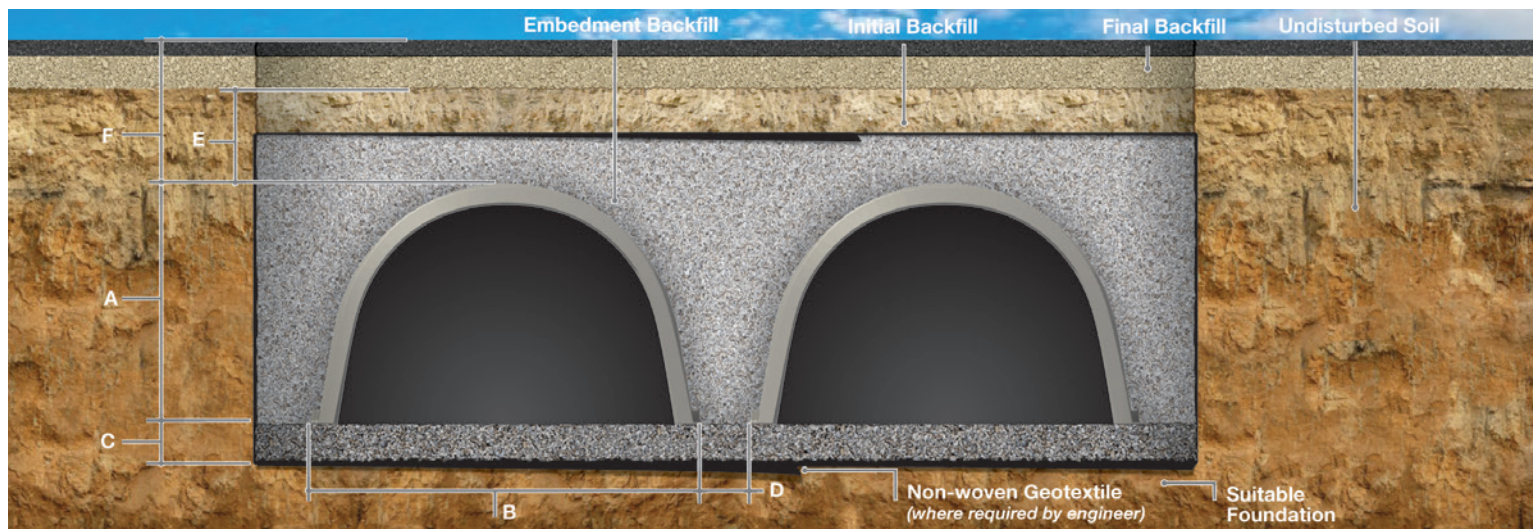

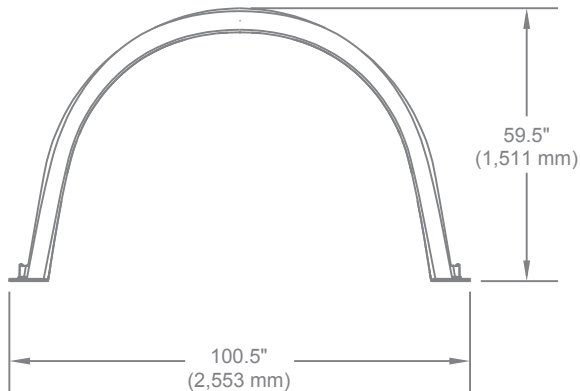

HydroStor® HS290 end view

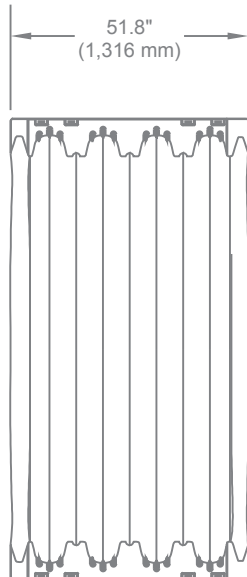

HydroStor® HS290 top view

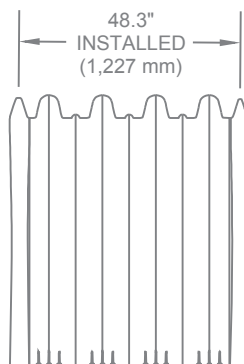

HydroStor® HS290 side view

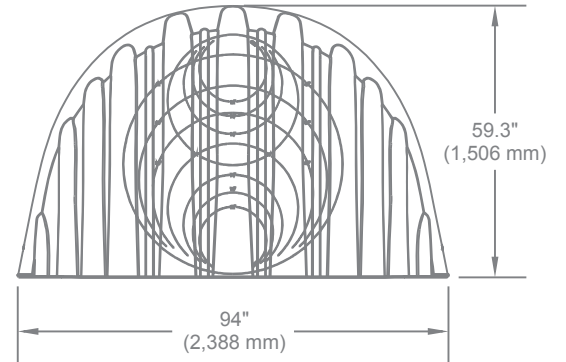

HydroStor® HS290 end cap end view

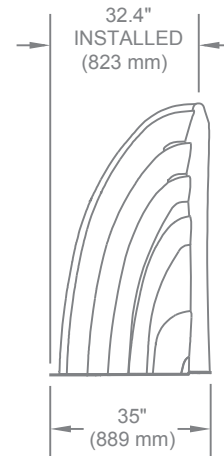

HydroStor® HS290 end cap side view

End Cap Specifications

End Cap Size (L x W x H)	35" x 94" x 59.3" (889 x 2,388 x 1,506 mm)
Installed Length	32.4" (823 mm)
End Cap Storage	39.6 ft ³ (1.12 m ³)
Minimum Installed Storage	114.46 ft ³ (3.1 m ³)
Weight	79.9 lbs (36.24 kg)

Shipping

Chambers/Pallet	10 Chambers
End Caps/Pallet	10 End Caps



Sediment Row

The Sediment Row is the row of chambers aligned with an inlet and placed on two layers of woven geotextile. The woven geotextile fabric filters the incoming stormwater and prevents sediment from migrating to open graded rock and other rows in the system. The specified geotextile resists the jetting forces introduced during cleaning operations.

The Sediment Row is designed with an access structure upstream to provide access for the cleaning jet. The access structure should be installed prior to the placement of the chambers and is designed to divert initial (first flush) flow into the Sediment Row with higher flows re-directed to the balance of the system through an elevated manifold.

System Cleaning

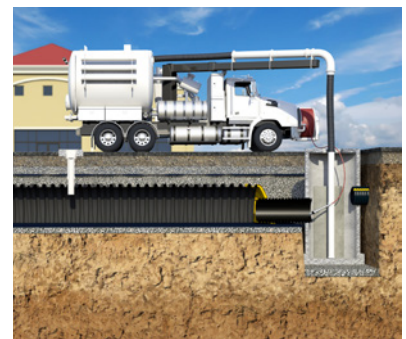
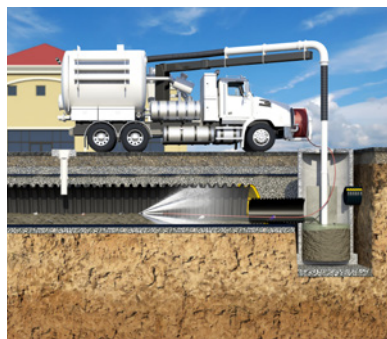
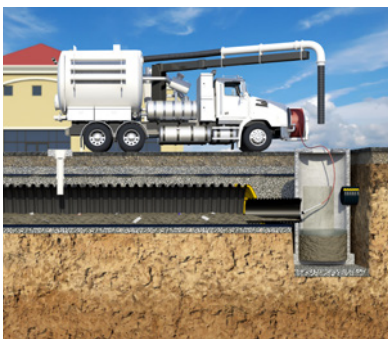

The most common method of cleaning is done by using a vacuum truck. For the sediment row, a high-pressure nozzle with rear-facing jets is used to direct the sediment and debris to the inlet control structure where it can then be vacuumed out. Care needs to be taken to ensure damage to the geotextile fabric does not occur when removing sediment and debris.

For detailed layout dimensions, refer to the Engineer's layout or Prinsco's standard Sediment Row detail.



Our Tech Centers

Prinsco is committed to achieving the highest level of customer service and product performance in the industry. As a result, we've created Tech Centers that provide focused areas of expertise and capabilities to benefit the customer experience.

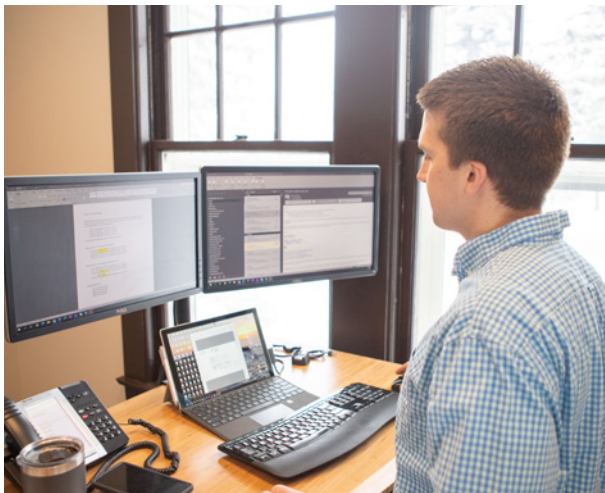

Engineering Tech Center

This facility is a unique location just blocks away from our corporate office. The Engineering Tech Center inspires collaboration, creativity, and focus among our full team of engineers covering application, product, process, and quality. It supports a customer-centric culture away from the distractions of daily operations.



Research Tech Center

This facility is designed to support the performance of existing and future Prinsco products. The Research Tech Center houses our product development lab along with a centralized materials lab for testing incoming resin streams on behalf of our national network of manufacturing centers. It is also home to one of the industry's largest, most comprehensive joint testing technologies for use by our team and other third-party testers.



Prinsco Delivers Quality

Prinsco delivers quality from manufacturing right down to the service we provide on delivery.

The charts below give approximate full-load quantities for a Prinsco 48 and 53 foot trailer. The quantities may vary according to the length of the trailer or if common carriers are employed for shipment. In mixed-size load situations, calculate the percentage of the load that each size will constitute. Then total the percentages to determine the extent of the load. The chart is strictly “rule of thumb” to give you a general idea of load quantities. For more specific figures, call our customer service department.

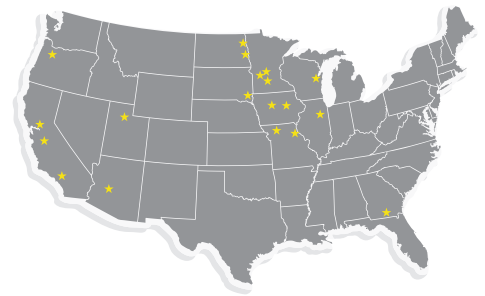

HydroStor® - 48' Trailer

	HS31 Chamber	HS31 End Cap	HS75 Chamber	HS75 End Cap	HS180 Chamber	HS180 End Cap	HS290 Chamber	HS290 End Cap
Delivery	Flatbed	Dry Van	Flatbed	Dry Van	Flatbed	Dry Van	Flatbed	Dry Van
# Pallets	8 Pallets	20 Pallets	11 Pallets	20 Pallets	7 Pallets	10 Pallets	10 Pallets	7 Pallets
# Items	720 Chambers	1,200 End Caps	363 Chambers	400 End Caps	133 Chambers	120 End Caps	100 Chambers	70 End Caps

HydroStor® - 53' Trailer

	HS31 Chamber	HS31 End Cap	HS75 Chamber	HS75 End Cap	HS180 Chamber	HS180 End Cap	HS290 Chamber	HS290 End Cap
Delivery	Flatbed	Dry Van	Flatbed	Dry Van	Flatbed	Dry Van	Flatbed	Dry Van
# Pallets	9 Pallets	22 Pallets	12 Pallets	22 Pallets	8 Pallets	12 Pallets	11 Pallets	8 Pallets
# Items	810 Chambers	1,320 End Caps	396 Chambers	440 End Caps	152 Chambers	144 End Caps	110 Chambers	80 End Caps

NESTING/TELESCOPING: All sizes through 36" will nest in the next larger size.

FITTINGS: Many of our fittings and accessories are packed in bags or bundles. For quantity packs, refer to catalog pages.



prinsco.com

800.992.1725