

DETAIL A:  
THERMOPLASTIC LINER DETAIL

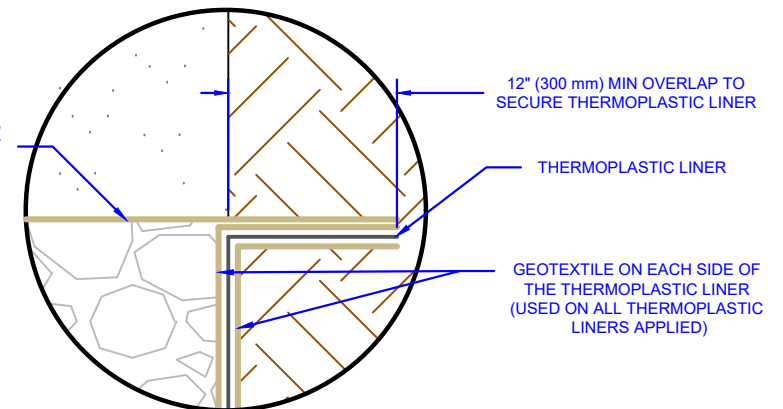

**NOTES:**

1. REFERENCE "HYDROSTOR HS75 - CROSS SECTION (D-7-300A)" FOR ALL ACCEPTABLE FILL MATERIAL & PROPER INSTALLATION OF CHAMBER SYSTEM.
2. THERMOPLASTIC LINER ON BOTTOM AND SIDES OF SYSTEM ONLY.
3. THERMOPLASTIC LINERS OPTIONS INCLUDE:
  - POLYVINYL CHLORIDE (PVC), 30 MIL PVC
  - LINEAR LOW DENSITY POLYETHYLENE (LLDPE), 30 MIL LLDPE
  - REINFORCED POLYPROPYLENE (RPP), EPDM, AND XR-5
4. AN AASHTO M288 CLASS 2 OR 3 NON-WOVEN GEOTEXTILE SHALL BE PLACED ON BOTH SIDES OF THERMOPLASTIC TO PROTECT AGAINST ANGULAR AGGREGATE ON THE WATER SIDE AND FROM PROTRUSION ON THE SOIL SIDE AT ANY LOCATION IN THE SYSTEM (SEE THERMOPLASTIC LINER DETAILS)
5. THERMOPLASTIC LINER AND PIPE BOOTS SHALL BE INSTALLED PER THE MANUFACTURERS INSTALLATION RECOMMENDATIONS.

5A- A PIPE BOOT WITH CLAMP IS RECOMMENDED WHEN PIPE PENETRATES THOUGH THE LINER. BOOTS CAN EITHER BE PREFABRICATED BY THE LINER MANUFACTURE OR FIELD FABRICATED BY THE CONTRACTOR.

5B- FOR A WATERTIGHT BOOTED CONNECTION, IT IS RECOMMENDED TO TRANSITION TO A SMOOTH WALL PIPE (E.G. PVC). THIS CAN BE DONE IN MANY WAYS: MARMAC DISSIMILAR COUPLER, FERNCO COUPLER, HARCO HUB X SDR35 SPIGOT ADAPTER WITH GASKET, OR ANY OTHER APPROVED CONNECTOR TO TRANSITION FROM CORRUGATED PLASTIC PIPE. THE PROJECT ENGINEER SHALL DECIDE ON WHAT PIPE MATERIAL PENETRATES THE LINER.

ONE LAYER OF AN AASHTO M288 CLASS 2 OR 3 NON-WOVEN GEOTEXTILE ABOVE EMBEDMENT BACKFILL (WHERE REQUIRED BY ENGINEER)