

Chamber Specifications	
Chamber Size (L x W x H)	87.1" x 51.0" x 29.7" (2,210 x 1,300 x 754 mm)
Installed Length	84.9" (2,160 mm)
Chamber Storage	46.6 ft ³ (1.32 m ³)
Min. Installed Storage*	75.0 ft ³ (2.12 m ³)
Weight / Chamber	69 lbs (31 kg)
Chambers / Pallet	33
Approx. Weight / Pallet	2,360 lbs (1,070 kg)

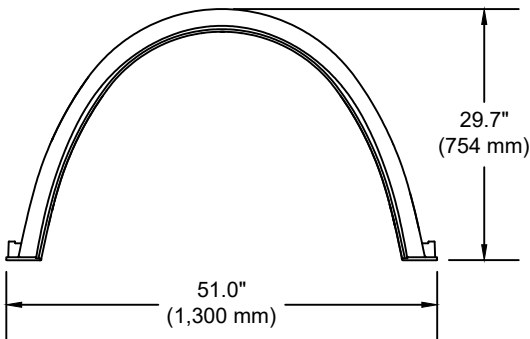

End Cap Specifications	
End Cap Size (L x W x H)	11.9" x 51.0" x 30.2" (302 x 1,300 x 767 mm)
Installed Length	10.4" (264 mm)
End Cap Storage	3.42 ft ³ (0.09 m ³)
Min. Installed Storage*	14.5 ft ³ (0.41 m ³)
Weight	13.2 lbs (5.99 kg)

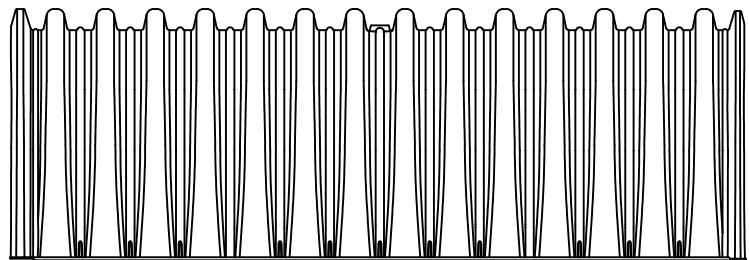
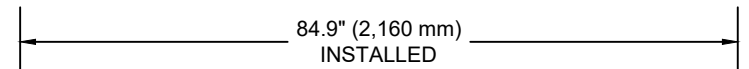
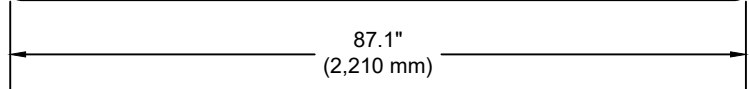
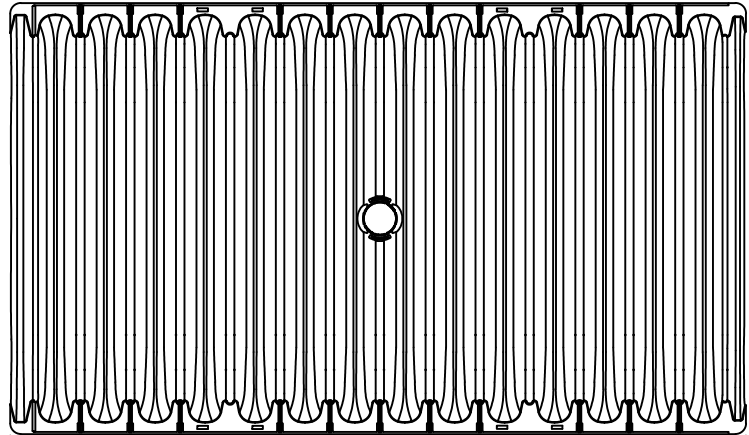
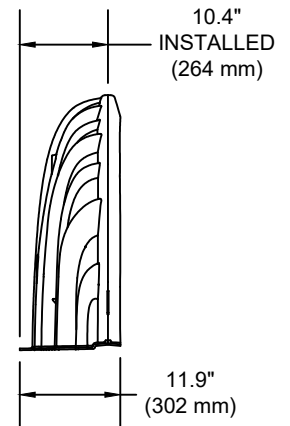
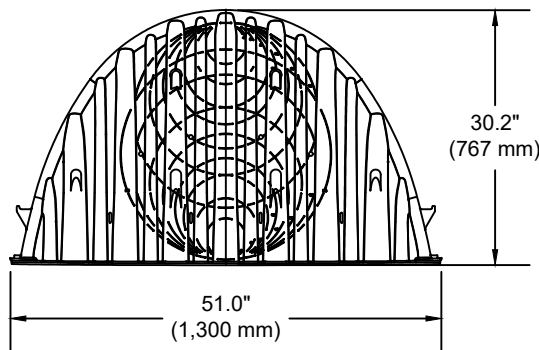

*ASSUMES 6" (150 mm) STONE ABOVE CHAMBERS/END CAPS, 6" (150 mm) OF STONE FOR FOUNDATION STONE, 6" (150 mm) OF STONE BETWEEN CHAMBERS/END CAPS, 12" (300 mm) OF STONE PERIMETER IN FRONT OF END CAPS AND 40% STONE POROSITY.

THIS DETAIL DEPICTS RECOMMENDED INSTALLATION PRACTICES AND IS NOT INTENDED TO SUPERSEDE ANY NATIONAL, STATE OR LOCAL SPECIFICATIONS. PRINSCO BEARS NO RESPONSIBILITY FOR ANY ALTERATIONS, REVISION AND/OR DEVIATION FROM THIS STANDARD DETAIL. PRINSCO HAS NOT PERFORMED ANY ENGINEERING OR DESIGN SERVICE FOR THIS PROJECT. THE DESIGN ENGINEER SHALL REVIEW THESE DETAILS PRIOR TO CONSTRUCTION TO VERIFY SUITABILITY. © PRINSCO, INC.



1717 16TH ST. NE
WILLMAR, MN 56201
www.prinSCO.com

TITLE: HYDROSTOR HS75 - SPECIFICATION		DRAWN BY: AED		DATE: 04-Sep-24		DRAWING NUMBER: D-7-301	
		SCALE: NTS		SHEET: 1 OF 1			